

# **ROTORWAY HELICOPTER MANUFACTURING COMPANY**

## **A600**

# **PILOT OPERATING HANDBOOK**

This helicopter must be operated in compliance with the operating limitations defined in this handbook.

Registration No. \_\_\_\_\_

Serial No. \_\_\_\_\_

**THIS HANDBOOK SHOULD BE KEPT IN THE ROTORCRAFT  
AT ALL TIMES.**

Rev C Oct-24-2018

# WARNING

The construction and operation of "Home-Built Aircraft" of this type is demanding and could inflict serious injury and possible death. No such operation, construction or undertaking should be initiated unless thorough and complete knowledge, preparation and instruction are available and utilized. The seller (and its agents, servants, employees, contractors, successors, and assigns) makes no warranties express or implied regarding the clarity or correctness of the plans, ease of construction or operation, number of building hours required, nor the safety of this aircraft or any part thereof. Furthermore, buyer (and his heirs, administrators and assigns) releases and holds said seller (and its agents, servants, employees, contractors, successors, and assigns) harmless from any and all liability, damages, and causes of action which may be incurred by buyer or any third party as a result of the purchase, use, construction and/or operation of said aircraft (or any part thereof) or plans for same. Buyer assumes all risk and responsibility relative to the construction and/or operation of said aircraft. Seller admits no liability by publication of this warning.

## CONTENTS

<u>Section</u>	<u>Page</u>
1 RotorWay A600 Specifications .....	2
2 Limitations.....	3
3 Normal Procedures.....	5
4 Emergency Procedures .....	12
5 Performance .....	16
Height Velocity Envelope.....	17
Diagram of the Cyclic Control Area of Operation .....	18
Density Altitude Chart.....	19
6 Weight and Balance.....	20
Hang Test Diagram.....	22
Center of Gravity Calculations .....	23
Center of Gravity Limits Chart .....	26
7 FADEC System.....	27
Instrument Panel Lights Diagram .....	29
Overhead Switch Panel Diagram.....	31
8 Mandatory and Advisory Bulletins .....	32
9 A600 Turbo Engine Startup and Shutdown Procedure .....	33
10 Full Lotus Floats.....	35
Center of Gravity Limits With Full Lotus Floats .....	36
11 HELIPAC Cargo Container .....	37
RotorWay A600 Checklists .....	38

**Section 1. RotorWay A600 Specifications**

Powerplant .....	RI 600N liquid cooled, four stroke, 162 cubic inches (2659 cc)
Optional Powerplant (turbocharged) .....	RI 600T liquid cooled, four stroke, 162 cubic inches (2659 cc)
Seats .....	2
Maximum gross weight.....	1500 lbs. (680 kg)
Maximum gross weight (with optional turbocharger) .....	1630 lbs. (740 kg)
Empty weight.....	975 lbs. (442 kg)
Equipped useful load.....	525 lbs. (238 kg)
Fuel capacity .....	17 U. S. Gallons (64 liters)

## Section 2. Limitations

Maximum airspeed at sea level, standard day ..... 115 MPH (100 knots)

Reduce IAS ..... 2 MPH for each 1000 ft. density altitude

Maximum airspeed in turbulent air ..... 75 MPH (65 knots)

Maximum sideways, rearwards airspeed ..... 20 MPH (17 knots)

Fuel requirements ..... minimum 92 Octane auto fuel  
or 100 low lead AV gas (100LL)

Solo flight from left seat only (right seat belt must be buckled and passenger collective must be removed).

Flight with one or both doors removed is permitted. All items in the cabin must be secured.

Maximum gross weight..... 1500 lbs. (680 kg)

Maximum gross weight (with optional turbocharger) ..... 1630 lbs. (740 kg)

Minimum pilot weight (solo operation)..... 150 lbs. (68 kg)

Maximum Cabin Weight ..... 425 lbs. (193 kg)

Maximum per seat weight to be determined by PIC (Pilot In Command) using available Weight & Balance formulas and charts located in Section 6 of this manual.

### CAUTION

Under no circumstances shall the helicopter be flown if Fore & Aft and/or Lateral CG are not within limits (see chart on page 26).

### CAUTION

Under no circumstances shall the helicopter be flown if full range of all flight controls is not possible. The cyclic handle position is affected by weight and balance and should remain in the center during normal operations. The cyclic handle should fall within the 6-inch diameter control area of operation in a hover. The outside shaded area is for limited time use only and should be avoided (see diagram on page 18).

## Instrument Markings

Color code for instrument markings:

GREEN: Normal operating range

YELLOW: Cautionary operating range

RED: Indicates maximum operating limits. The pointer should not enter the red during normal operation.

Voltage:

Green arc .....12-1/2 to 14-1/2

Oil pressure:

Green arc ..... 40 – 70 PSI

Yellow arc ..... 70 – 80 PSI

Red line ..... above 80 PSI

Oil temperature:

Low yellow arc ..... 100° – 120°F

Green arc ..... 120° – 230°F

High yellow arc ..... 230° – 250°F

Red line ..... 250°F

Water temperature:

Green arc ..... 110° – 190°F

Yellow arc ..... 190° – 215°F

Red line ..... 215°F

Tail rotor gearbox temperature:

Caution (may vary according to regional climate) ..... 176°F

Alarm ..... 212°F

Rotor RPM:

Low red line ..... 90%

Low yellow arc ..... 90% – 96%

Green arc (100% = 520 RPM) ..... 96% – 104%

High yellow arc ..... 104% – 110%

High red line ..... 110%

Engine RPM:

Green arc ..... 96% – 104%

High red line ..... 110%

Operational RPM (standard) ..... 100% = 4250 RPM

Operational RPM (turbocharged) ..... 100% = 3900 RPM

Airspeed:

VNE ..... 115 MPH (100 knots)

## Section 3. Normal Procedures

### Pre-flight checks:

- A. Remove front inspection panel and check:
  - 1. Security and condition of pedals
  - 2. Security of front landing gear bracket
  - 3. Routing and security of all electric wiring
  - 4. Routing and security of the pitot lines
  - 5. Battery condition and connections
  
- B. Remove covers on the right and left seat backs and check:
  - 1. Torque link for cracks and security
  - 2. Lower bearing on the main shaft
  - 3. Condition of main drive belts
  - 4. Condition of the ignition systems
  - 5. All airframe tubes for cracks
  - 6. Oil level

**CAUTION:** Do not overfill the oil sump. If too much oil is added, the sump must be drained to the proper level. If any oil is spilled, it must be cleaned up before flight.

- C. Engine area right side check:
  - 1. For oil, fuel, and water leaks
  - 2. Security and routing of hoses, pipes, and wiring
  - 3. Heat shielding for cracks and clearance
  - 4. Security of the rear landing gear brackets
  - 5. Tail rotor gearbox belt drive and idler pulley
  
- D. Tail boom right side check:
  - 1. For cracks, wrinkles and structural security
  
- E. Vertical and Horizontal trim fin check:
  - 1. Structural security and angle
  - 2. Security of Winglets
  
- F. Tail rotor check:
  - 1. Freedom of travel
  - 2. Freedom and condition of the rod ends
  - 3. For cracks in the skins around the 3/16 retention bolts and pop rivets
  - 4. End play on the blades and security of the snap rings and pivot bolts

- G. Tail rotor drive check:
  - 1. Condition of front flex-coupling and gearbox for leaks
  - 2. Condition of 1st and 2nd shaft bearings on bulkheads
  - 3. Condition of rear flex-coupling and gearbox for leaks
  - 4. Oil level in rear gearbox
  - 5. Check security of tail rotor pitch cable attachment
  
- H. Tail boom left side check:
  - 1. For cracks, wrinkles, and structural security
  
- I. Engine area left side check:
  - 1. Oil, fuel, and water leaks
  - 2. Security and routing of hoses, pipes, lines, and wiring
  - 3. Condition and tension of the fan drive and main drive belts
  - 4. Clutch and idler pulley
  - 5. Security of the rear landing gear brackets
  - 6. For cracks and security of heat shielding
  
- J. Collective control check:
  - 1. Freedom of travel
  - 2. All linkages for security
  - 3. Throttle roll and butterfly travel
  
- K. Cyclic control check:
  - 1. Freedom of travel
  - 2. Bias of the cables and security of rod ends



## L. Doghouse check:

1. Travel of cog belt tensioner
2. Tail rotor drive belt for proper tension
3. Surge tank level

## M. Rotor system check:

1. Security and wear of the scissors
2. For cracks around the ears of the swash plate and the hood bracket
3. To see if washer and snap rings on the drive pin are loose
4. For loose bolts
5. Freedom and condition of both control rods

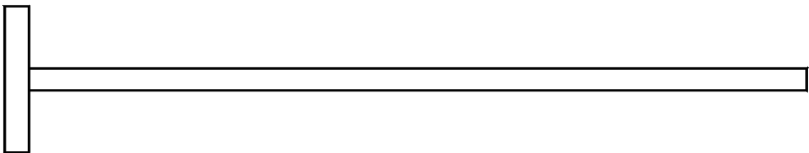
## N. Main rotor blades check:

1. Around bolts on retention straps for cracks
2. Bolts for signs of bending
3. Doublers for delamination
4. Blades for wrinkles or cracks near the root end
5. For separation of the skin to spar top and bottom
6. Security of the blade tip end plugs
7. Blade droop for any change
8. Friction of teeter blocks

## O. Fuel level:

1. Use a dip hose to check the amount of fuel in the tanks and to verify the accuracy of the fuel gauge.
2. Check fuel level and sample.

NOTE: To calibrate the dip hose, start with the fuel tanks empty and add a measured amount of fuel. Dip the hose all the way into the tank, up to the "T" handle. Take the hose out and permanently mark the fuel level with safety wire. (Insert the wire through the hose, then wrap and tie it securely around the hose.) Repeat the process for additional amounts of fuel. For future reference, record the marks and the corresponding fuel quantity on the dip hose drawing below.



**Before starting:**

1. Untie blades and preflight aircraft.
2. Check ballast weight location.
3. Position blade perpendicular to the aircraft.

**WARNING:** When the starter is engaged, all drive train components will turn, including the main rotor blades.

**NOTE:** If equipped with optional turbocharger, see **Section 9, A600 Turbo Engine Startup and Shutdown Procedure** on page 33, in addition to the information below.

**Starting (see Overhead Switch Panel Diagram on page 31):**

1. Set Altimeter
2. Fasten and adjust seat and shoulder belts.
3. Secure doors.
4. Check cyclic, collective, and pedals for full travel and freedom of travel.
5. Clutch disengaged.
6. Turn on fuel valve.
7. Turn on key and instrument switch.
8. Turn on FADEC 1 switch.
9. Turn on fuel pump #1 and both ignition switches and check fuel pressure (50–60 PSI).
10. Controls in start position.
11. Set throttle to 0% (if necessary, add throttle to start engine).
12. Clear area and engage starter.
13. After starting, check and monitor oil pressure (40 to 80 psi within 5 seconds) and water temperature (slowly rising). Adjust throttle for smooth idle (if necessary).
14. Engage clutch.
15. Turn on fuel pump #2, FADEC 2 and alternator. Check for voltage increase.
16. Test both ignitions, both fuel pumps, and both FADEC switches. All switches on when complete.
17. With the engine running, check FADEC system as follows: Turn off FADEC 1 switch. The green FADEC 1 light should go off and the red FADEC 1 light should come on. The engine should be running on the secondary system. Reset the primary system by switching FADEC 1 on, then turn off FADEC 2 to verify that FADEC 1 is operating independently. Turn FADEC 2 back on. The green FADEC 1 and 2 lights on the instrument panel should come on, and the red lights should be off.

(continued)

18. Turn on avionics.
19. Idle until water and oil temp is in the green.
20. Check fuel pressure, volt meter and over-running clutch.
21. Check cyclic position and instruments in the light position.

**After Started:**

Throttle .....closed while at idle

Cyclic .....keep centered below 400 RPM

**NOTE:** When operating the helicopter in sub-freezing temperatures, it may be necessary to restrict the air flow through the radiator. This will enable the water temperature to stabilize above 160° F during flight. See Engine Manual for further details

**Run up:**

- Oil temperature .....green
- Oil pressure .....green
- Water temperature .....green
- Pedals..... centered
- Cyclic ..... centered
- Collective lever ..... set 3° to 3-1/2° positive
- Throttle ..... slowly increase to 100% rotor RPM

**NOTE:** During run up and run down, engine operation between 2500 and 3000 RPM should be limited due to main drive belt resonance frequency.

**Take off:**

- Pedals..... even to half right pedal
- Cyclic ..... within 3 inches of center

The pilot should determine the correct control position during take off by noting and responding to the small movements of the aircraft when it becomes light on the skids.

Slowly raise collective, adjusting throttle to maintain rotor RPM in the green.

Economical cruise ..... manifold pressure 4 inches less than hover  
Rotor RPM 101% ..... must maintain in green at all times

Take off and operation should be conducted per height velocity envelope diagram (see page 17).

During flight, check all instruments for anomalies.

**NOTE:** If the yellow light on the instrument panel illuminates during flight, the helicopter should be safely landed. The pilot can identify the problem and respond accordingly. If the red light illuminates during any operation of the aircraft, the aircraft should be landed immediately and the problem determined and resolved before resuming flight.

**CAUTION: DO NOT RESET THE PRIMARY SYSTEM IN FLIGHT IF THE SECONDARY SYSTEM IS IN OPERATION.**

**After Landing:**

Collective lever ..... lower to 3° pitch  
 Throttle ..... close to idle when securely on the surface

**Shutdown:**

1. Idle at zero throttle until water and oil temp reduce from operating temp. (minimum 10° oil temp. drop).
2. Turn off both fuel switches.
3. When engine stops, turn off fuel valve.
4. Turn off all switches.
5. Disengage clutch.
6. Remain inside helicopter until blades stop.
7. Post flight checks.

**Post flight checks:**

Swash plate bearing ..... check temperature  
 Main thrust bearing ..... check temperature  
 Upper secondary bearing ..... check temperature (170° to 190° F)  
 Tail boom ..... check for wrinkles  
 Tail rotor ..... inspect  
 Vertical stabilizer ..... secure  
 Engine Compartment ..... inspect left and right side  
 Main rotor blades ..... tie to tail boom

## Section 4. Emergency Procedures

### Engine failure General:

A change in noise level, a right yaw and low oil pressure may be the first indication of an engine failure.

- A. Engine failure below approximately 4 feet AGL:
  - 1. Maintain level attitude with cyclic.
  - 2. Apply left pedal as required to prevent yawing.
  - 3. Collective pitch should not be reduced by any significant extent.
  - 4. Increase collective just before touchdown to cushion landing.
  
- B. Engine failure between 4 feet and 10 feet AGL:
  - 1. Lower collective lever to maintain rotor RPM. The amount of and duration of collective reduction depends upon the height above the ground at which the engine failure occurs.
  - 2. Use cyclic and collective as required to carry out engine off landing.
  - 3. Maintain heading with pedals.
  - 4. Increase collective before touchdown to cushion landing.
  
- C. Engine failure at altitude:
  - 1. Lower collective to maintain rotor RPM and enter normal autorotation (see page 15).
  - 2. Establish a steady autorotation descent at approximately 70 MPH.
  - 3. Adjust collective to keep rotor RPM 100%.
  - 4. After a steady autorotation is established, select a landing spot and maneuver as required so the landing will be upwind.
  - 5. A restart may be attempted at pilot's discretion, if sufficient time is available.
  - 6. If unable to restart, turn off unnecessary switches and shut off the fuel valve if sufficient time is available.
  - 7. At about 35 feet AGL, begin a cyclic flare to reduce forward and descent speed. Level at 3 to 5 feet of clearance between the tail rotor and the ground. Increase collective pitch to cushion ground contact as the aircraft settles below 30 inches AGL, maintaining heading with the pedals.
  
- D. Maximum glide distance configuration:
  - 1. Airspeed 65 MPH.
  - 2. Rotor RPM 96%
  - 3. Increase rotor RPM to 101% when below 500 feet AGL.

- E. Engine fire in flight:
1. Enter autorotation.
  2. Shut off fuel pumps then fuel valve if time is available.
  3. Execute an autorotation landing. After landing, if time permits, turn off ignition, instrument and alternator switches.
  4. Extinguish fire and inspect for damage.
- F. Electrical fire in flight:
1. FADEC, instrument, ignition, and fuel pump switches on.\*
  2. All other switches off.
  3. Land immediately.
  4. Turn remaining switches off.
  5. Extinguish fire and inspect for damage.
- \* (**NOTE:** Do not switch ignition off unless the engine has stopped).
- G. Air restart procedure:  
Set throttle to zero. Press starter button on the cyclic.

**CAUTION: IF AN ENGINE MALFUNCTION OCCURS, DO NOT ATTEMPT A RESTART UNTIL A SAFE AUTOROTATION IS ESTABLISHED.**

- H. Tachometer failure:  
If the rotor or engine tach malfunctions in flight, use the operational tach to make a normal landing.

- I. Tail rotor failure during hover:
  - 1. Failure is usually indicated by a left yaw which can not be corrected by applying right pedal.
  - 2. Immediately close the throttle and perform a hovering power off landing.
  - 3. Keep the ship level with the cyclic and increase the collective just before touchdown to cushion landing.
  
- J. Tail rotor failure during forward flight:
  - 1. Failure is usually indicated by a right or left yaw which can not be corrected by applying pedal.
  - 2. Immediately enter a shallow descent into the wind.
  - 3. **CAUTION: If sideslip is excessive and the aircraft tends to spiral, immediately enter an autorotation and plan a power off landing, (full touchdown auto) with throttle off.**
  - 4. Adjust the collective and the throttle to extend the glide **ONLY** if sideslip is not excessive and the aircraft does not tend to spiral. Select a landing site and perform a run-on landing, touching down at a speed well above translational lift, using throttle to maintain heading. **CAUTION: Attempting a run-on landing with a tail rotor failure requires extreme pilot skill.**
  
- K. Engine fire during starting on the ground:
  - 1. Turn off fuel pumps.
  - 2. Turn off fuel valve.
  - 3. Turn off all other switches if time permits.
  - 4. Extinguish the fire with a fire extinguisher or whatever is available.
  - 5. Inspect for damage.



**Autorotation Procedure From Altitude:**

1. Lower collective **FULL DOWN**, apply left pedal to maintain trim, adjust cyclic to maintain level attitude.
2. Adjust collective to maintain rotor RPM within the green (100%).
3. Adjust airspeed to 70 MPH (65 to 75 MPH limit).
4. Begin cyclic flare at approximately 35 feet AGL using approximately 30 degree flare angle. Level aircraft at 3 to 5 feet of clearance between the tail rotor and the ground. Rotor RPM should typically increase 5 to 7% during the flare.
5. During level off, add collective pitch if you are settling too rapidly.
6. Allow aircraft to settle to 30 inches AGL. As the aircraft settles below 30 inches, apply collective pitch to cushion ground contact.

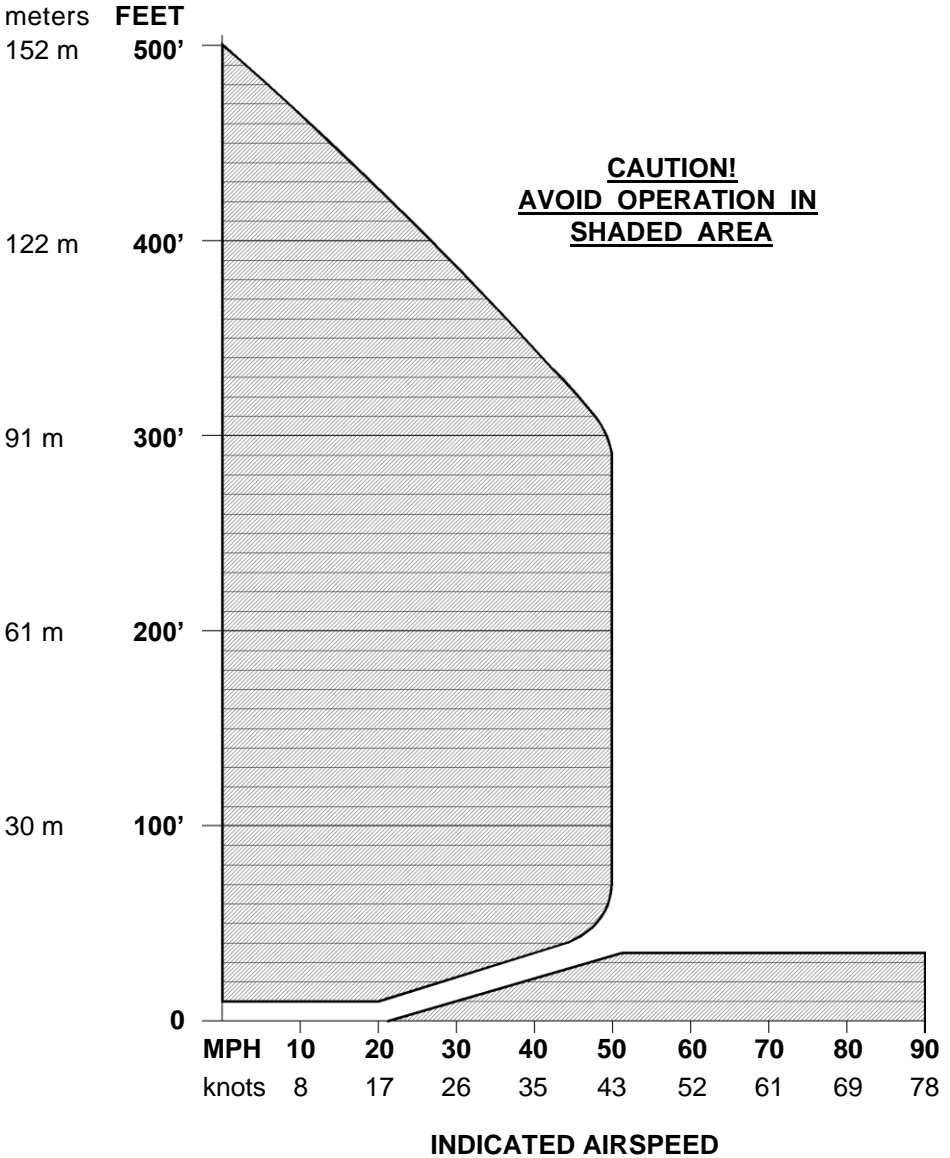
**NOTE: AUTOROTATION TO THE GROUND IS NOT RECOMMENDED DURING TRAINING AND PRACTICE.**

**Section 5. Performance**

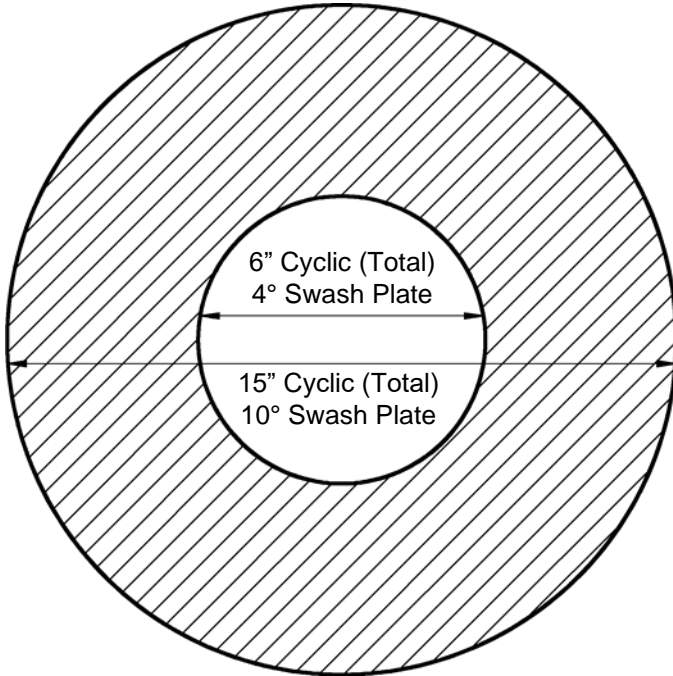
Hover in ground effect .....	Standard 7000 feet (2133 m)
	With turbocharger 9000 feet (2743 m)
Hover out of ground effect .....	Standard 5000 feet (1524 m)
	With turbocharger 7000 feet (2133 m)
Service ceiling .....	Standard 10,000 feet (3048 m)
	With turbocharger 11,500 feet (3500 m)
Range with maximum fuel at best range speed of 85 MPH (74 knots) .....	
.....	180 miles/2hrs. (289 kilometers)
Normal cruise .....	75 to 95 MPH (82 knots)
Maximum airspeed .....	115 MPH (100 knots)

### HEIGHT VELOCITY ENVELOPE

NOTE: Out of ground effect (O.G.E) hovers are prohibited for all A600 pilots under 150 hours.

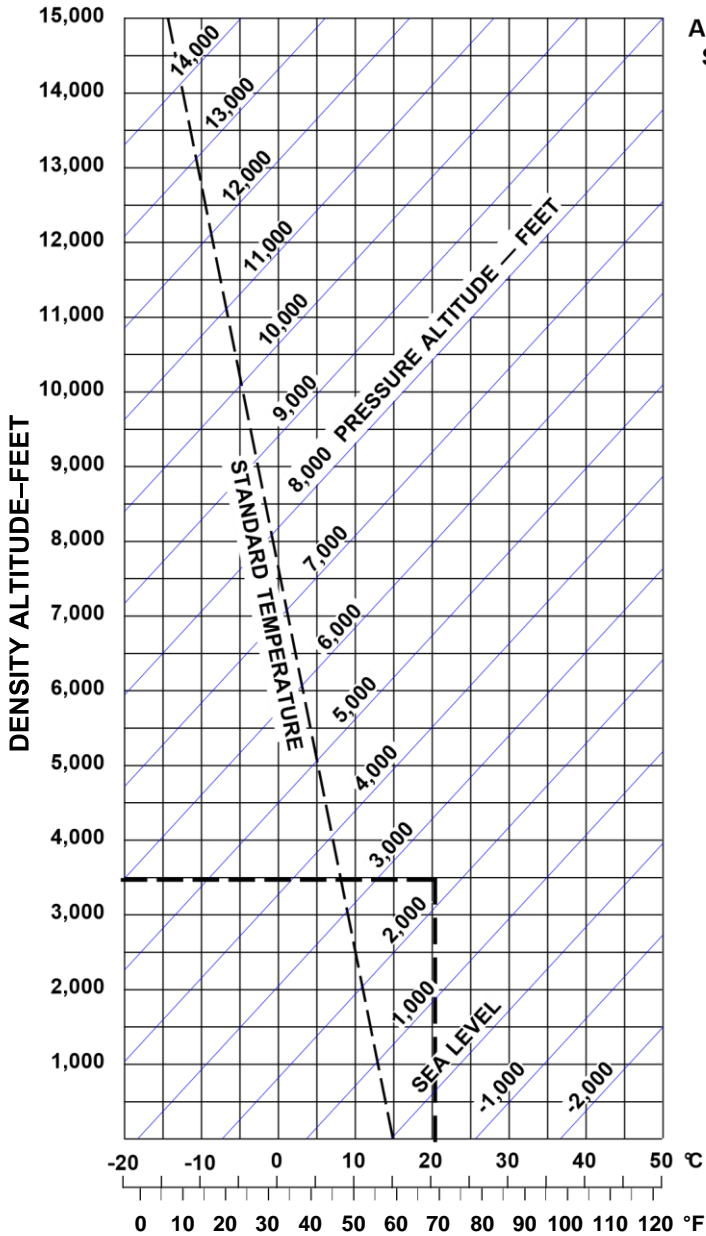


**DIAGRAM OF THE CYCLIC CONTROL  
AREA OF OPERATION**



1. Cyclic handle position is affected by weight and balance.
2. The helicopter must be rigged in compliance with the rigging instructions provided.
3. The cyclic handle should remain in the center during normal operations.
4. The shaded circle is for limited time use only.

## DENSITY ALTITUDE CHART



Altimeter Setting (inHg)	Pressure Altitude Conversion Factor
--------------------------	-------------------------------------

28.0	1,824
28.1	1,727
28.2	1,630
28.3	1,533
28.4	1,436
28.5	1,340
28.6	1,244
28.7	1,148
28.8	1,053
28.9	957
29.0	863
29.1	768
29.2	673
29.3	579
29.4	485
29.5	392
29.6	298
29.7	205
29.8	112
29.9	20
29.92	0
30.0	-73
30.1	-165
30.2	-257
30.3	-348
30.4	-440
30.5	-531
30.6	-622
30.7	-712
30.8	-803
30.9	-893
31.0	-983

Example: Pressure altitude 2,200 (altimeter set at 29.92)  
 Temperature 70° F = Density Altitude 3,500 ft



For this test to be accurate the aircraft must be complete with the following:

1. Full coolant and oil in aircraft
2. No fuel in tanks
3. Enclosed area, no wind

There will be three test configurations of the aircraft, each with a different cabin loading. If the helicopter falls within plus or minus 1/2 degree both laterally and fore/aft of the specified angles of the three tests, and if the helicopter has been properly rigged, the aircraft should be ready for the first run-ups and liftoffs.

**NOTE:** During all tests the main rotor blades must remain in the fore and aft position (parallel to the tail boom). Values do not include doors or avionics package.

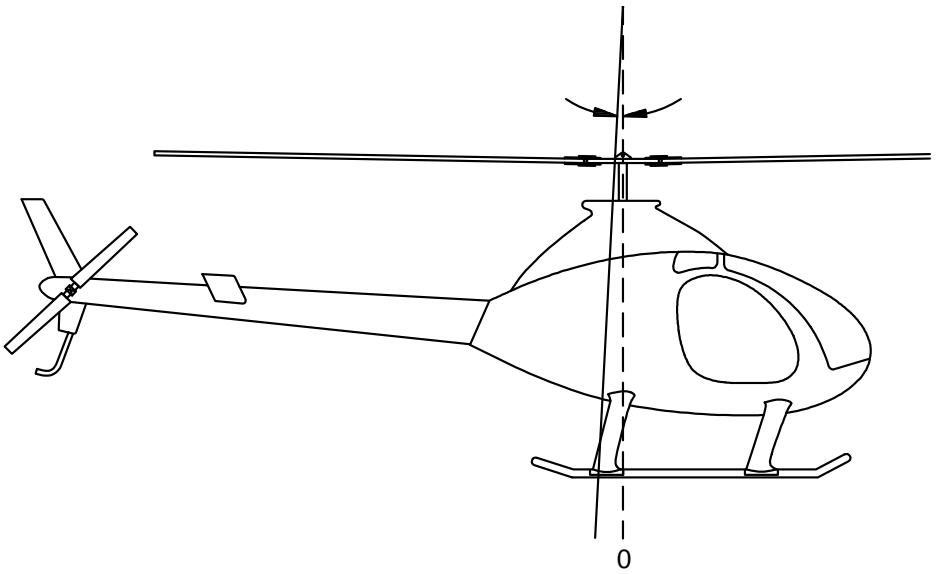
Using the Hang Test Diagram on page 22, the following results should be obtained within 1/2 degree (plus or minus) in all three tests:

- A. EMPTY AIRCRAFT (no cabin weight, ballast weight in solo front skid location):
  - Fore and Aft .....3° aft
  - Lateral ..... 2° passenger side
- B. PILOT ONLY 150 lbs. (ballast weight in solo front skid location):
  - Fore and Aft ..... 1° fore
  - Lateral .....0 °
- C. PILOT 210 lbs. and PASSENGER 210 lbs. (ballast weight in rear dual location):
  - Fore and Aft .....3° to 5° fore
  - Lateral ..... 1/2° passenger side

The results of these tests should be recorded in the appropriate columns on the diagram provided on page 22.

**IMPORTANT:** If you are unable to achieve the results specified above within plus or minus 1/2 degree, contact RotorWay Customer Service Department for assistance before attempting to lift off the aircraft. The weight and balance of any helicopter is critical, and this helicopter should not be flown until the pilot is aware of the weight and balance schedule and the hang test has been satisfactorily performed.

### HANG TEST DIAGRAM



Fore and Aft Measurements:

A. \_\_\_\_\_

B. \_\_\_\_\_

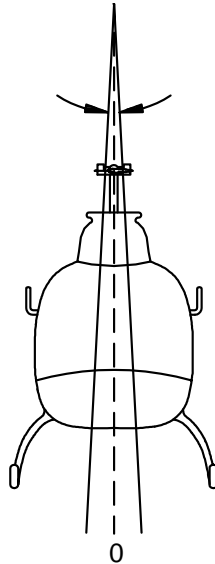
C. \_\_\_\_\_

Lateral Measurements:

A. \_\_\_\_\_

B. \_\_\_\_\_

C. \_\_\_\_\_





### Center of Gravity \*

In addition to the hang test, it will be necessary to find the aircraft's center of gravity. Place the aircraft on scales at the forward and rear weighing points as shown in the illustration below. (Exact placement is shown in the diagram on page 24.) Then, using the example on page 25, calculate the center of gravity of your helicopter.

#### FORE/AFT

SCALE 1 + SCALE 3 = FORE TOTAL

SCALE 2 + SCALE 4 = AFT TOTAL

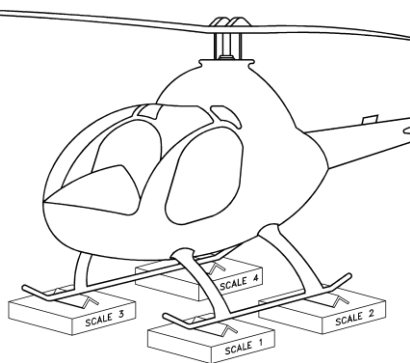
#### LATERAL

SCALE 1 + SCALE 2 = LEFT TOTAL

SCALE 3 + SCALE 4 = RIGHT TOTAL

SCALE 1 + 2 + 3 + 4 EQUALS

TOTAL AIRCRAFT EMPTY WEIGHT



### WEIGHT AND BALANCE CALCULATIONS (EMPTY WEIGHT)

No ballast weight, no fuel in aircraft.

Weight x Arm Inch = Moment Inch

Total Moment Inch ÷ Total Weight = Balance Location

FORE / AFT	<u>WT.LBS</u>	<u>ARM INCH</u>	<u>MOMENT INCH LBS.</u>
Front Scales (Fore Total)	_____ x _____		= _____
Rear Scales (Aft Total)	_____ x _____		= _____
TOTAL WT.	_____	TOTAL MOMENT	_____

LATERAL	<u>WT.LBS</u>	<u>ARM INCH</u>	<u>MOMENT INCH LBS.</u>
Pilot Skid (Left Total)	_____ x _____		= _____
Pass. Skid (Right Total)	_____ x _____		= _____
TOTAL WT.	_____	TOTAL MOMENT	_____

TOTAL WEIGHT: \_\_\_\_\_ FORE/AFT CG: \_\_\_\_\_ LATERAL CG: \_\_\_\_\_

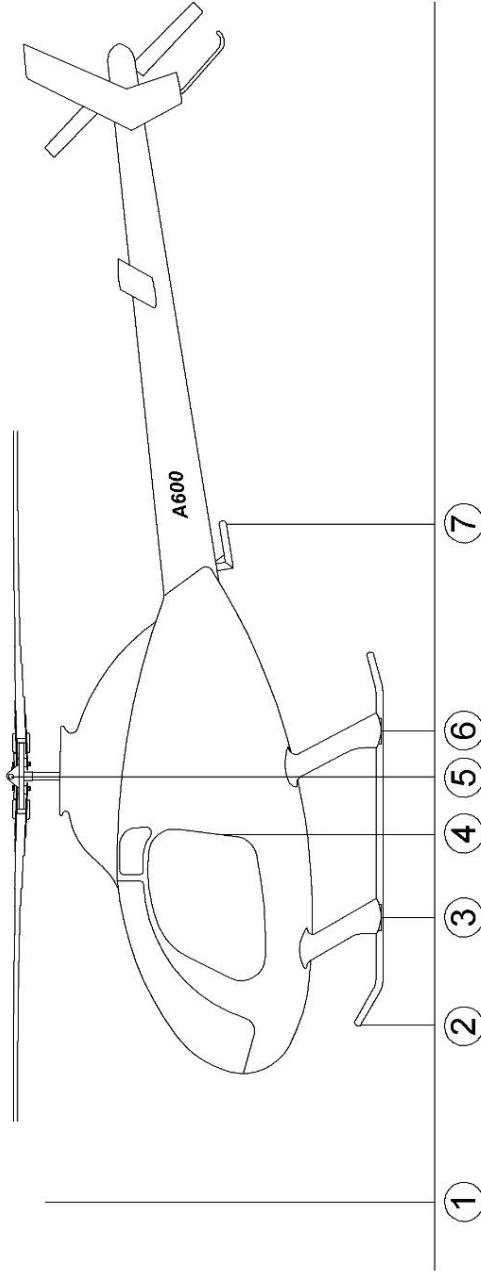
**\* NOTE: THE MAIN ROTOR SHAFT MUST BE 90° TO THE GROUND WHEN THE AIRCRAFT IS WEIGHED. MAKE SURE TO SUBTRACT THE WEIGHT OF ANYTHING ON THE SCALES THAT IS NOT PART OF THE HELICOPTER (ANGLE BARS, WOOD BLOCKS, ETC.) SOME ERROR CAN OCCUR ON THE FORWARD SCALE VALUES IF THE SKIDS DO NOT SET SQUARE TO THE GROUND OR SCALES.**

**FORE/AFT ARM INCH**

- 1. DATUM ..... 0
- 2. FORWARD WEIGHT POSITION ..... 26.0
- 3. FORWARD WEIGHING POINT ..... 55.75
- 4. SEATS ..... 71.0
- 5. MAIN SHAFT AND GAS TANKS ..... 100.0
- 6. REAR WEIGHING POINT ..... 109.25
- 7. REAR WEIGHT POSITION ..... 163.0

**LATERAL ARM INCH**

- PASSENGER SKID ..... +37.5R
- PASSENGER SEAT ..... +10.5R
- PASSENGER GAS TANK ..... +18.5R
- PILOT SKID ..... -37.25R
- PILOT SEAT ..... -10.25L
- PILOT GAS TANK ..... -18.25L



**DATUM SCALE IS GRADUATED IN INCHES. THESE CALCULATIONS ARE DETERMINED WITH THE MAIN ROTOR SHAFT 90 DEGREES TO THE GROUND WHEN THE AIRCRAFT IS WEIGHED.**

**SAMPLE WEIGHT AND BALANCE  
AIRCRAFT ON SCALES**

No ballast weight, no fuel in aircraft

Weight x Arm Inch = Moment Inch

Total Moment Inch ÷ Total Weight = Balance Location

<b>FORE / AFT</b>	<b>WT. LBS</b>		<b>ARM INCH</b>		<b>MOMENT INCH LBS.</b>
Front Scale	71	x	55.75	=	3958.25
Rear Scale	853	x	109.25	=	93190.25
	924				97148.50

97148.50 ÷ 924 = **105.13 FORE / AFT CG LOCATION**

<b>LATERAL</b>	<b>WT. LBS</b>		<b>ARM INCH</b>		<b>MOMENT INCH LBS.</b>
Passenger Skid	474	x	31.5+	=	14931.0
Pilot Skid	450	x	31.25-	=	14062.5-
	924				868.5

868.5 ÷ 924 = **.94+ LATERAL CG LOCATION**

---

**SAMPLE WEIGHT AND BALANCE  
SOLO FLIGHT**

<b>FORE / AFT</b>	<b>WT. LBS</b>		<b>ARM INCH</b>		<b>MOMENT INCH LBS.</b>
Basic Weight	924	x	105.13	=	97140.12
Ballast Wt. Forward	27	x	37.25	=	1005.75
Pilot	210	x	71.00	=	14910.00
Fuel	60	x	100.00	=	6000.00
	1221				119055.87

119055.87 ÷ 1221 = **97.50 FORE / AFT CG LOCATION**

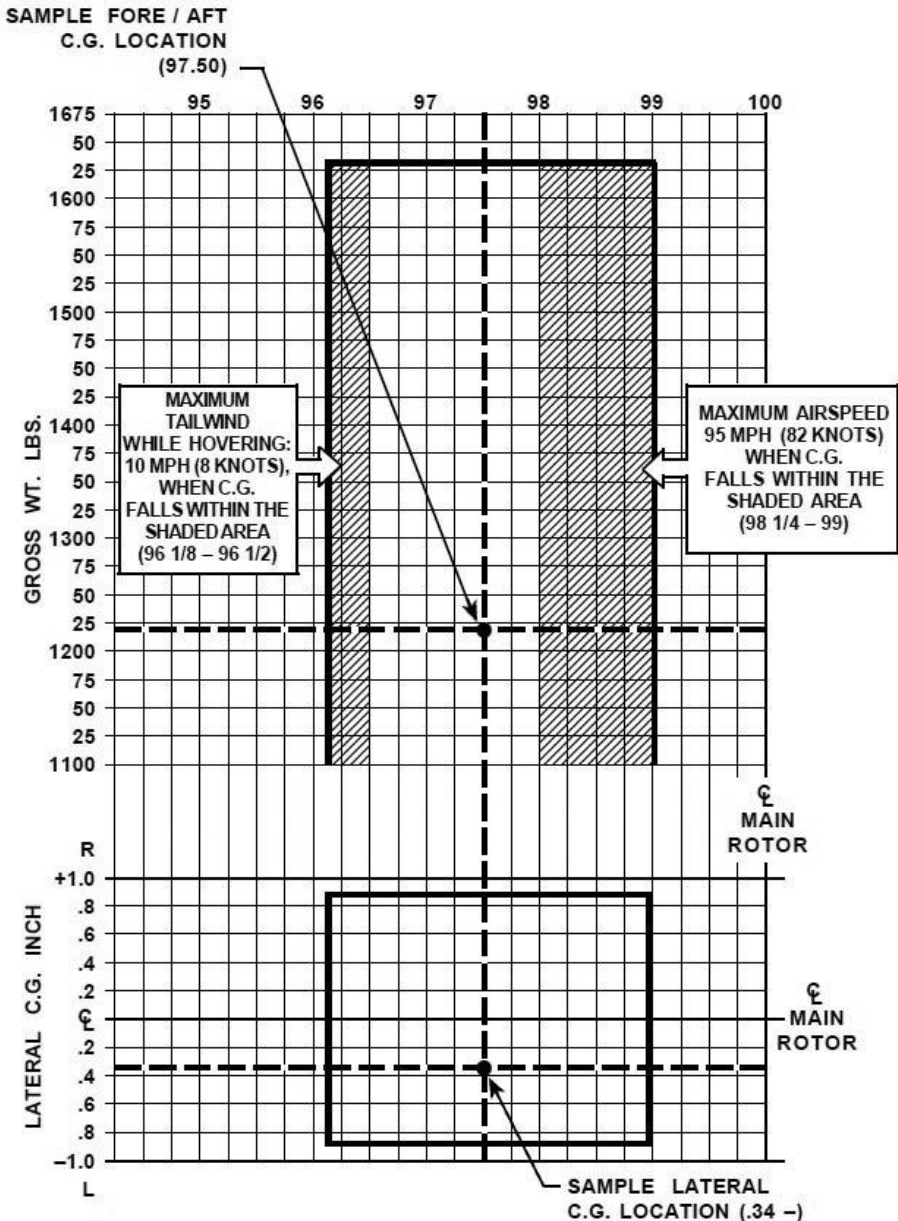
(See chart on page 26)

<b>LATERAL</b>	<b>WT. LBS</b>		<b>ARM INCH</b>		<b>MOMENT INCH LBS.</b>
Basic Weight	924	x	.94	=	868.5+
Ballast Wt. Pass. Skid	27	x	31.50+	=	850.5+
Pilot	210	x	10.25-	=	2152.5+
Fuel Pilot	30	x	18.25-	=	547.5-
Fuel Pass.	30	x	18.50+	=	555.0+
	1221				426.0-

426- ÷ 1221 = **.34- LATERAL CG LOCATION**

(See chart on page 26)

## ROTORWAY A600 CENTER OF GRAVITY LIMITS



**YOUR AIRCRAFT MUST NOT BE OPERATED OUTSIDE OF THE LIMITS  
DEFINED ON THIS GRAPH.**

## **Section 7. FADEC System**

RotorWay's FADEC (Fully Automated Digital Electronic Control) is an electronic engine control system that is unique in the aviation industry. The system is fully redundant; if failure of the primary system occurs, a backup system will automatically activate.

this page intentionally left blank

## Instrument Panel Lights

Lights on the instrument panel indicate the following:

**ENGINE WARNING LIGHT, RED:** Engine has stopped or dropped below 1800 RPM

**ECU 1, GREEN:** FADEC System is activated and operating on primary ECU

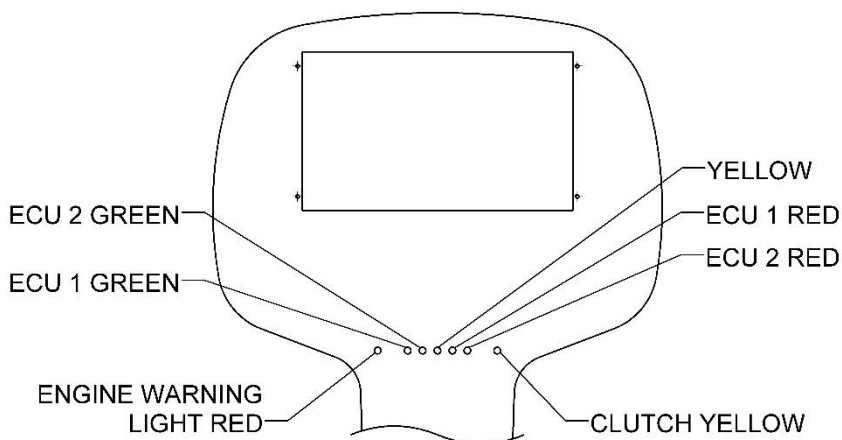
**ECU 2, GREEN:** Secondary ECU is on standby if primary ECU is active; or secondary ECU is operating if primary ECU is off.

**YELLOW:** An error has occurred

**ECU 1, RED:** The primary ECU is off

**ECU 2, RED:** The secondary ECU is off

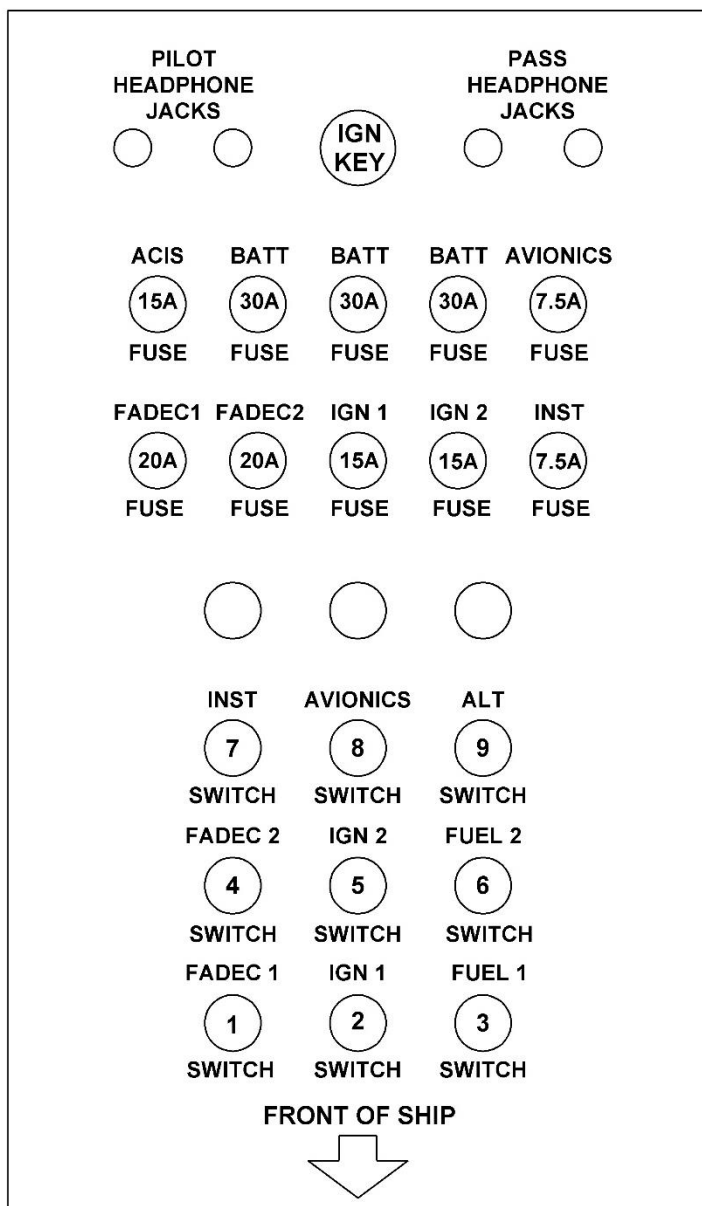
**CLUTCH, YELLOW:** The clutch switch is activated



this page intentionally left blank



## OVERHEAD SWITCH PANEL DIAGRAM (AS VIEWED FROM BELOW)



## **Section 8. Mandatory and Advisory Bulletins**

A Mandatory bulletin contains information that RotorWay has determined to be important to the safe operation of the helicopter. Mandatory bulletins **MUST** be complied with. An Advisory bulletin contains information about recommended improvements, accessories, or procedures, although compliance is not mandatory.

Modifications referred to in a bulletin are incorporated into production on or before the date the bulletin is issued. Therefore, when an A600 helicopter is shipped, it is in compliance with all bulletins issued up to the shipping date.

## **Section 9. A600 Turbo Engine Startup and Shutdown Procedure**

- Follow startup checklist in the A600 Pilot Operating Handbook. Oil return pump is controlled by the key switch. When key switch is in the ON position oil pump will be on. Pump must be on for the duration of engine operation.
- Make sure a proper pre-flight inspection is performed. Make sure clamps holding the inlet tubes are tight.
- Always confirm oil pressure on start up.
- Let engine warm up to minimum of 122 degrees F or 50 degrees Celsius before takeoff.
- Operate helicopter as normal.

### **Performance differences**

- Throttle position sensor will read approximately 35 to 40% when helicopter will enter hover. Hover should easily be achieved with around 40% throttle position with two people and full fuel.
- Overall throttle position during flight will be 10 to 20% less than with normal engine.
- Oil temperatures should be lower than before due to improvements in oil channels in the engine and proper installation of the oil cooler.
- Fuel burn will be 9 gallons (34 liters) per hour.
- During the testing phase, closely monitor temperatures, oil pressure and throttle position.
- Use only 20w-50 oil.

### **Shutdown Procedure**

- Make sure oil temperature is at or below 187 degrees F or 86 degrees Celsius.
- Shut down engine as normal except keep key switch on for 30 seconds after shutdown. Oil pump must run to drain oil from turbo. If pump is not left on for 30 seconds, oil will leak from turbo.

## **Section 9. A600 Turbo Engine Startup and Shutdown Procedure**

- Follow startup checklist in the A600 Pilot Operating Handbook. Oil return pump is controlled by the key switch. When key switch is in the ON position oil pump will be on. Pump must be on for the duration of engine operation.
- Make sure a proper pre-flight inspection is performed. Make sure clamps holding the inlet tubes are tight.
- Always confirm oil pressure on start up.
- Let engine warm up to minimum of 122 degrees F or 50 degrees Celsius before takeoff.
- Operate helicopter as normal.

### **Performance differences**

- Throttle position sensor will read approximately 35 to 40% when helicopter will enter hover. Hover should easily be achieved with around 40% throttle position with two people and full fuel.
- Overall throttle position during flight will be 10 to 20% less than with normal engine.
- Oil temperatures should be lower than before due to improvements in oil channels in the engine and proper installation of the oil cooler.
- Fuel burn will be 9 gallons (34 liters) per hour.
- During the testing phase, closely monitor temperatures, oil pressure and throttle position.
- Use only 20w-50 oil.

### **Shutdown Procedure**

- Make sure oil temperature is at or below 187 degrees F or 86 degrees Celsius.
- Shut down engine as normal except keep key switch on for 30 seconds after shutdown. Oil pump must run to drain oil from turbo. If pump is not left on for 30 seconds, oil will leak from turbo.

this page intentionally left blank

## Section 10. Full Lotus Floats

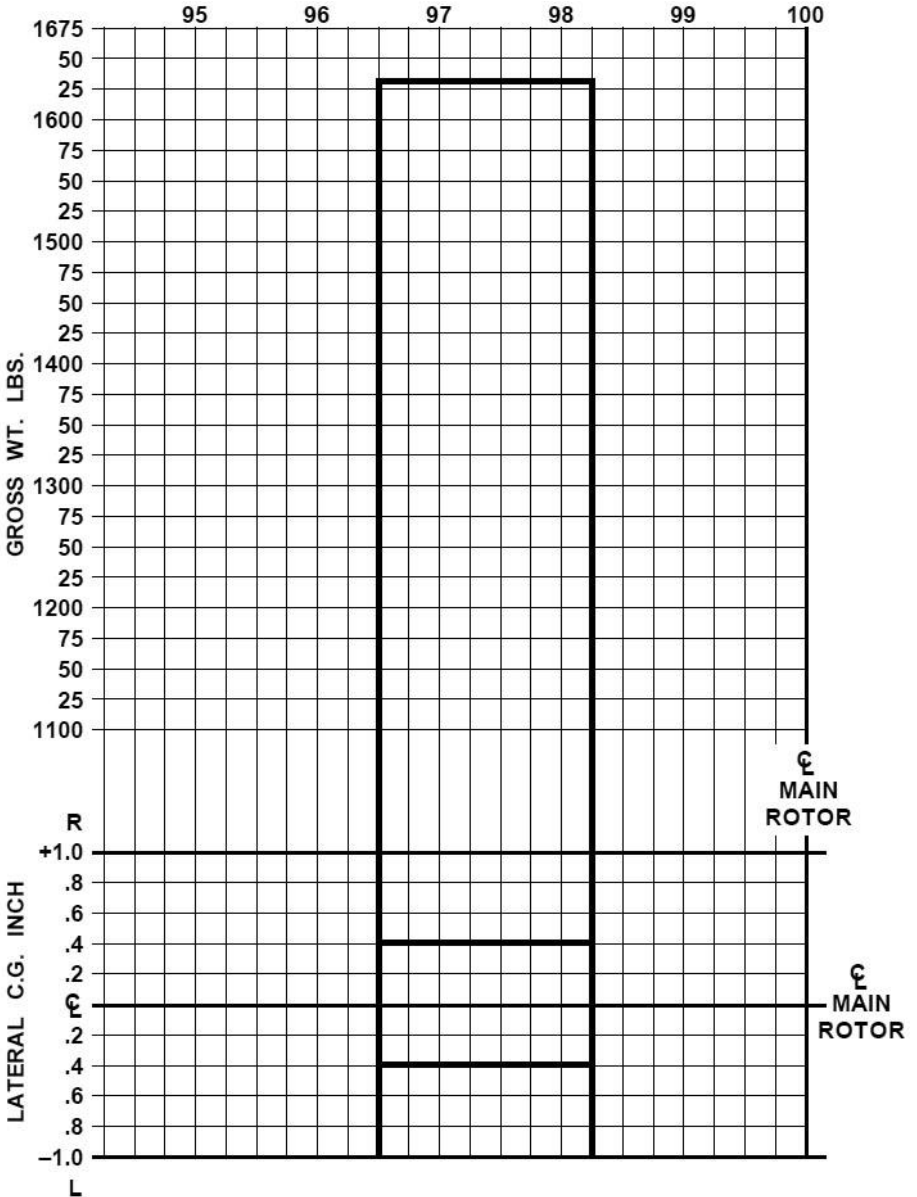
- A. The aircraft airspeed red line ( $V_{ne}$ ) at standard conditions is reduced to 80 MPH (69 knots) when flying the aircraft configured with floats.
- B. The fore/aft center of gravity limits change to 96.5 and 98.25 inches, and the lateral limits to -.4 and +.4 inches (see chart on next page).  
**NOTE:** The weight of the float system is not included in the calculation when finding the location of the balance point on the chart.
- C. The horizontal trim fin must have 4 degrees positive pitch (leading edge turned upward) added to the existing setting to compensate for the additional drag on the aircraft.
- D. No sliding of the aircraft on the floats is allowed during take off or landing on any surfaces except water. Damage may occur to the bottom side of the float if sliding occurs.
- E. The complete weight of the float system must be subtracted from the useful load of the aircraft.

### Pilot Observations/Precautions:

Any helicopter that is equipped with inflated floats requires a competent pilot with a higher knowledge and skill level. The following observations were noted and should be realized by any pilot prior to flying with an inflated float system.

- A. While hovering the aircraft, most if not all of the ground effect cushion is lost, which results in almost all hover conditions being out of ground effect.
- B. During autorotation, two situations will be different than during normal flight:
  - 1. The floats attempt to push the aircraft into an inverted position, thus a higher skill of cyclic control is required.
  - 2. The floats cause the air going through the rotor system to be turbulent, thus the pilot must be more cautious of rotor RPM and flare at the bottom of the autorotation.

### ROTORWAY A600 CENTER OF GRAVITY LIMITS WITH FULL LOTUS FLOATS



## Section 11. HELIPAC Cargo Container

- A. The Helipac unit must be installed according to the directions provided by RotorWay.
- B. The container may be slid toward the pilot's side for easier access while loading and unloading. However, it must be in the centered position during flight, and the safety bolt must be installed to prevent the container from moving during flight.
- C. All cargo must be secured and must not be allowed to shift inside the container during flight, or it will affect the aircraft's center of gravity. The eye bolts at the four inside corners of the container can be used to attach bungee cords, straps, or other anchoring devices. The caution label must be applied to the inside of the container in a place where it is clearly visible.
- D. The weight of the Helipac unit and any cargo must be subtracted from the useful load of the aircraft.
- E. Weight and balance with cargo in Helipac:  
With cargo in the container, the location and the amount of weight must be considered and added when calculating weight and balance.

### **Fore and aft arm inch**

Empty Helipac.....Station 88"

### **Lateral arm inch**

Empty Helipac.....Station 0"



**A600 START UP, RUN UP AND TAKE OFF CHECKLIST**

1. VERIFY FUEL QUANTITY USING CALIBRATED DIP HOSE.
2. UNTIE BLADES AND PREFLIGHT AIRCRAFT.
3. CHECK BALLAST WEIGHT LOCATION.
4. POSITION BLADE 45 DEGREES TO THE AIRCRAFT.
5. FASTEN SEAT AND SHOULDER BELTS.
6. CHECK CONTROLS.
7. CLUTCH DISENGAGED.
8. TURN ON FUEL VALVE (DOWN).
9. TURN ON KEY AND INSTRUMENT SWITCH.
10. TURN ON FADEC 1.
11. TURN ON FUEL PUMP 1 AND BOTH IGNITIONS. CHECK FUEL PRESSURE.
12. CONTROLS IN START POSITION.
13. SET THROTTLE TO 0% (IF NECESSARY, ADD THROTTLE TO START).
14. CLEAR AREA AND ENGAGE STARTER.
15. AFTER STARTING, CHECK AND MONITOR OIL PRESSURE AND WATER TEMPERATURE. ADJUST THROTTLE FOR SMOOTH IDLE.
16. ENGAGE CLUTCH.
17. TURN ON FUEL PUMP 2, FADEC 2 AND ALTERNATOR. CHECK FOR VOLTAGE INCREASE.
18. TEST BOTH IGNITIONS, BOTH FUEL PUMPS AND BOTH FADEC SWITCHES. ALL SWITCHES ON WHEN COMPLETE.
19. TURN ON AVIONICS.
20. IDLE UNTIL WATER AND OIL TEMP IS IN THE GREEN.
21. CHECK FUEL PRESSURE, VOLT METER AND OVER-RUNNING CLUTCH.
22. CHECK CYCLIC POSITION AND INSTRUMENTS IN THE LIGHT POSITION.

**A600 LANDING, COOL DOWN AND SHUT OFF CHECKLIST**

23. IDLE AT ZERO THROTTLE UNTIL WATER AND OIL TEMP REDUCE FROM OPERATING TEMP.
24. TURN OFF BOTH FUEL SWITCHES.
25. WHEN ENGINE STOPS, TURN OFF FUEL VALVE.
26. TURN OFF ALL SWITCHES.
27. DISENGAGE CLUTCH.
28. REMAIN INSIDE HELICOPTER UNTIL BLADES STOP.
29. POST FLIGHT CHECK.