

# **Section 20**

## **Fuel System**

**Procedures covered in this section:**

Open holes for fuel tank caps and sender; flush fuel tanks; install fuel tank strainer fittings, crossover fittings, and return fitting; install fuel tanks; fabricate and install retention straps and fuel drain cock mounting bracket; install fuel pumps, shut-off valve/filter assembly, fuel filter, fuel pressure regulator, and all fuel hoses.

**Cards used in this section:**

HARDWARE CARD      E25 CARD 2F  
E25 CARD 1F          E25 CARD 3F

**Prints used in this section:**

E25-2000  
E25-2001

**Templates used in this section:**

E25-1

**Tools required for this section:**

Air or electric drill	Grinder	Scissors	Vise
Allen wrench	Metal cutting snips	Screwdrivers	
Band saw or hacksaw	Pop rivet gun	Soldering iron	
Files	Ruler	Tape Measure	

Drill bits of the following sizes: 1/8", 3/16", 1/4", 5/16", #40

Ratchet with sockets of the following sizes: 3/8", 7/16", 1/2", 9/16"

Wrenches of the following sizes: 3/8", 7/16", 1/2", 9/16", 5/8", 11/16", 3/4", 13/16", 7/8", 15/16"

**Notes:**

1. FUEL SENDER: Refer to directions supplied with the sender. Also see calibration instructions in Section 26.
2. FUEL HOSES: Allow ample hose length for engine movement.
3. TEFLON TAPE: Use teflon tape on all fittings with pipe threads (NPT) in this assembly. Pipe threads are tapered so that they seal across the threads. Do not use Teflon tape on the other fittings, such as the AN aluminum hose ends. These types of fittings have a machined chamfer which creates a positive seal. Unlike pipe threads, these will NOT seal better by being tightened more, and can be damaged by over tightening.

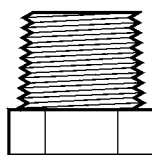

**NPT FITTING**

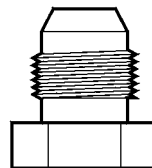

**AN FITTING**

4. FUEL TANKS: The seat bulkhead should be bolted to the airframe and the upper body panels should be temporarily installed to properly locate the fuel tanks. The seat belts should also be installed before mounting the fuel tanks (refer to Section 22 for seat belt installation).

## **PREFACE**

The Exec 162F is equipped with RotorWay's unique FADEC electronic engine control system and fuel injection. In this system, gasoline is delivered to the injectors at a VERY HIGH PRESSURE, 54 PSI. (By comparison, the fuel pressure of earlier RI 162 engines with carburetors was about 4 PSI.) Because of this, only the best quality hoses and fittings are used. When installing the fuel system components, be aware of the following:

1. Before installing the fuel hoses, flush them thoroughly with solvent and blow them dry with compressed air. Carefully inspect the insides of the hoses for any dirt or debris. Apply a light film of engine oil to the threads and chamfers of the fittings.
2. The braided steel hoses should be routed so that they curve smoothly without being kinked or sharply bent.
3. The steel braiding on the hoses is **EXTREMELY ABRASIVE**. Once the engine is running, vibrations will cause the braid to wear through whatever it comes in contact with, just like a file. **BECAUSE OF THIS, THE HOSES MUST BE POSITIONED SO THAT THEY DO NOT CONTACT OR RUB ON ANYTHING ELSE**. If a braided steel hose must touch another component, cut a length of rubber hose, wrap it around the braided hose, and secure it with wire ties.
4. The aluminum hose ends and fittings can be damaged if over tightened. To get the right amount of leverage, grip the wrench about 3 or 4 inches from the fitting.
5. Do not turn on the fuel pumps or add fuel to the system until the helicopter is ready for the first start-up. Before adding any fuel to the system, double check the tightness and security of all fittings. When fuel is pumped through the hoses for the first time, wear eye protection and have a fire extinguisher nearby. The pressure of this system can cause fuel to be sprayed surprisingly far and fast.

The two fuel tanks drain simultaneously so that the lateral center of gravity of the helicopter is not affected. The tanks are made from a cross-linked polyethylene plastic material noted for its durability. A similar fuel tank made from aluminum would be 10 to 15% lighter, however there would be no comparison in strength. Be sure to check for leakage, especially around fittings, upon final installation of the tanks.

**IMPORTANT:** Before operation, be sure that the heat shielding material has been taped to the fuel tanks and that the shields on the exhaust manifolds have been properly installed. Extended hovering maneuvers, such as those which will be performed during your initial learning to hover stage, should be done with the lower fuselage cowlings removed to ensure a continuous ambient fuel temperature. This will also allow easy access to the fuel, oil and cooling systems to inspect for leaks during the first few hours of operation.

**Photo #1**

Use prints E25-2000, E25-2001, E37-2000 and template E25-1 when installing the fuel system. Parts as received from RotorWay International.

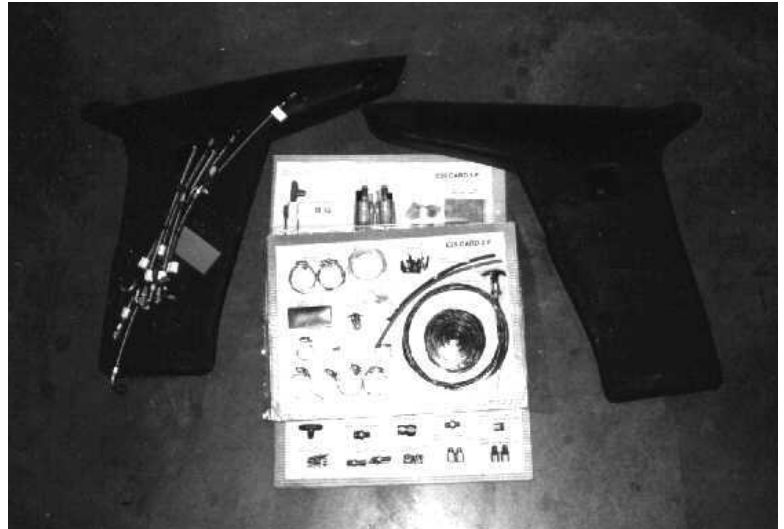

**Photo #2**

Use an air grinder or a drill to make holes in the fuel tanks where the caps and fuel gauge sender will go. The hole for the sender needs to be only large enough to allow the sender tube to be installed. The material is approximately 3/16" thick in these locations. Be careful not to gouge the fuel tank wall directly below the filler cap holes. Finish trimming out the excess material with a knife, grinder, or file. The surface that contacts the cap seal should be smooth and flat. If necessary, use a file or sandpaper to achieve this.

Note: A template and instructions are included in the box with the sender. Also see calibration instructions in Section 26.

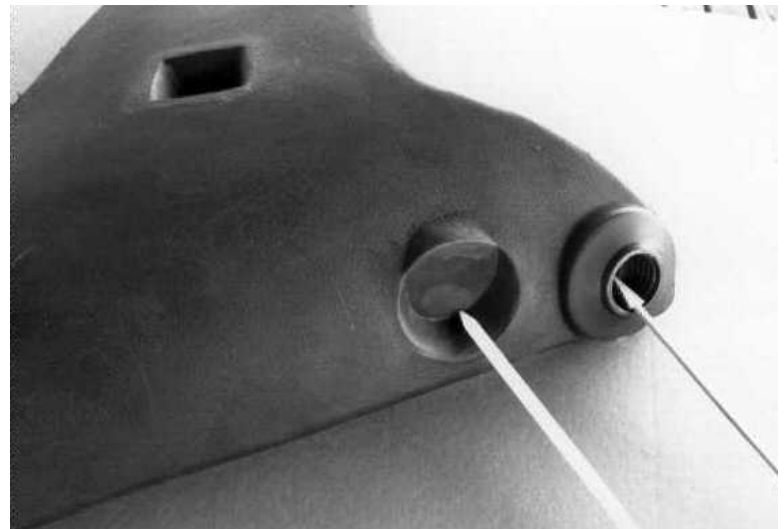
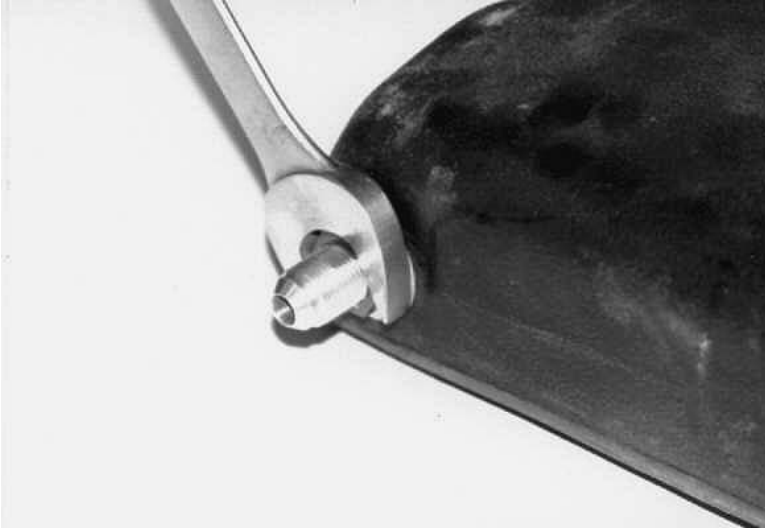

**Photo #3**

Deburr the inside and outside of the holes on the bottom of the tanks. Flush both tanks thoroughly with water to remove plastic chips and debris. Be sure the tanks are completely dry before connecting any hoses or fittings.

For each tank, assemble a fuel tank strainer fitting (refer to print E25-2001) and install it in the hole as shown.





**Photo #4**

Tighten the nut to 7-10 ft. lbs. Do not allow the rubber seal to turn inside the hole or it may damage the seal.

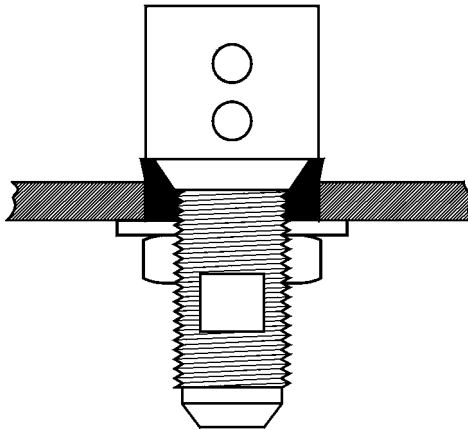

**Photo #5**

This shows the fitting after installation. When connecting the fuel lines, a wrench may be used on the flats in the threaded area to keep the assembly from turning. Be careful not to damage the threads. Always remember to apply a light film of oil to the threads when connecting aluminum fittings to prevent galling.

Note: Check tightness before adding fuel. Check again and re-tighten to 7-10 ft. lbs. if necessary after the first 5 hours of engine operation.



**Photo #6**

Install the crossover fittings in both tanks near the filler cap holes. Use Teflon tape on the threads. Install the fuel gauge sender, using the instructions provided with the sender kit.

**Photo #7**

Glue the rubber strips on the fuel tank brackets and airframe. Leave a gap in the rubber for the shoulder harnesses in the drive tube area.  
Note: It may be necessary to grind away clearance for the lower fitting and hose so that it will not rub against the bracket.



**Photo #8**

Install the heat shielding on the tanks as shown. Use the aluminum tape to hold it in place.

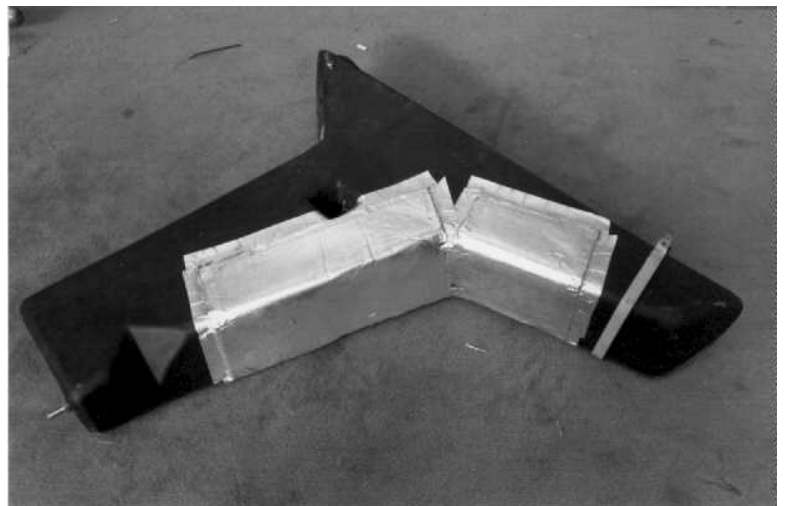

**Photo #9**

The seat bulkhead should be bolted to the airframe and the upper body panels should be temporarily installed to properly locate the fuel tanks. The seat belts should also be installed before mounting the fuel tanks (refer to Section 22 for seat belt installation).

The tanks can be held in position with duct tape and safety wire until they are ready to be permanently mounted. Allow 1/2" clearance between the fiberglass seat bulkhead and the fuel tank.





**Photo #10**

Position the top edge of the fuel tank filler nipple 1/2" to 5/8" below the fiberglass cowling. It may be necessary to raise the fuel tanks off of the brackets for best fit. This can be done with rubber or hardwood.

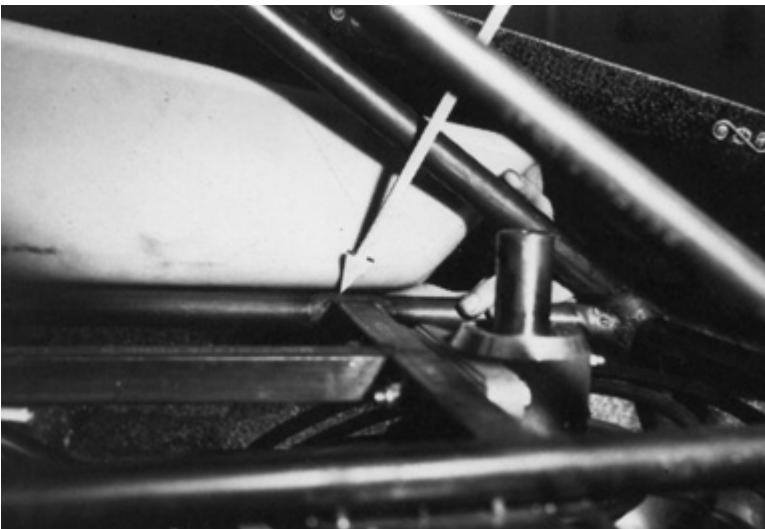

**Photo #11**

Position the rear of the fuel tank 1/8" above the top of the airframe tube as shown.

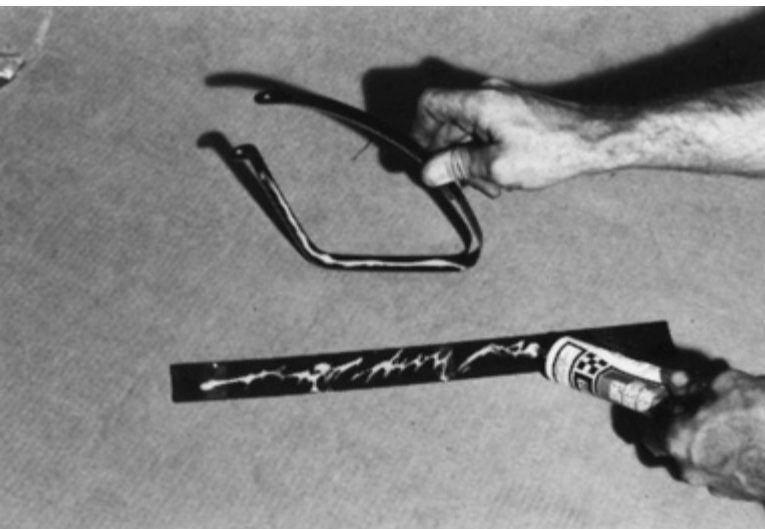
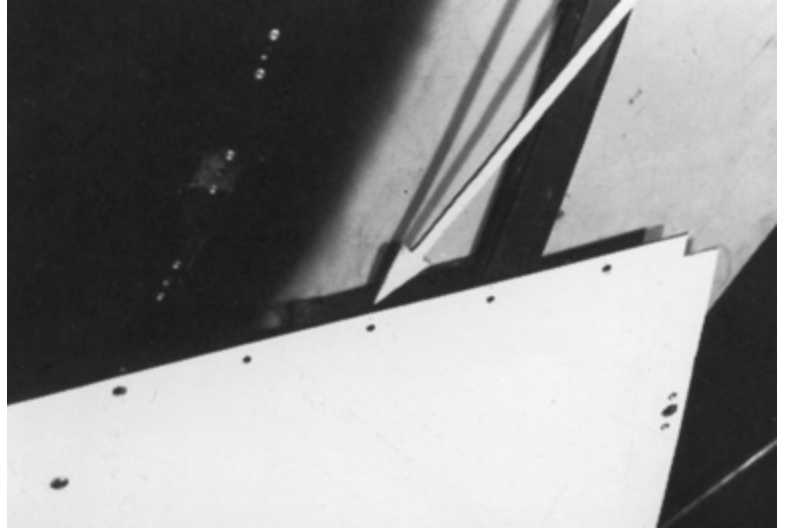

**Photo #12**

Fabricate the retention straps to hold the fuel tanks. (See print E25-2000.) Allow 1/8" clearance for the thickness of the rubber strips. Glue the rubber strips to the retention straps with weatherstrip adhesive.

**Photo #13**

If there is any place where a nut plate may come in contact with the fuel tank, shield that particular area by gluing a small piece of rubber stripping to the fuel tank.



**Photo #14**

This photo shows the rear of the fuel tank mounted to the airframe.



**Photo #15**

Note the clearance between the fuel tank and the body.



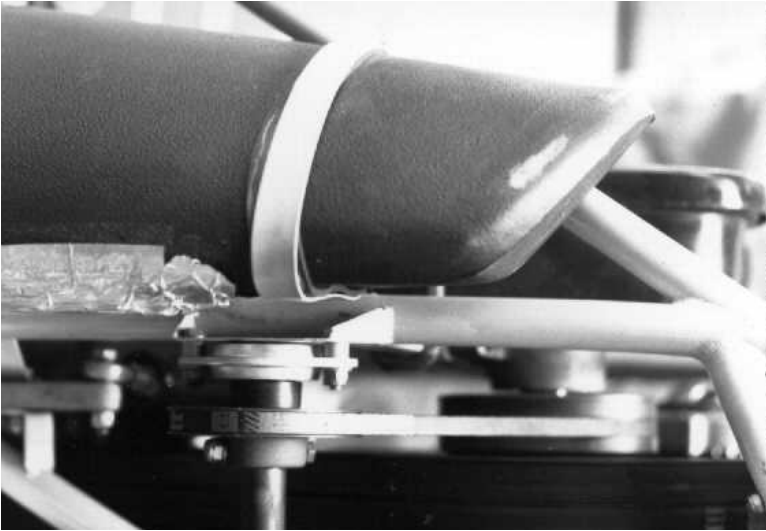

**Photo #16**

Be sure the rear bottom of the fuel tank does not rub on the fan drive on the pilot side.

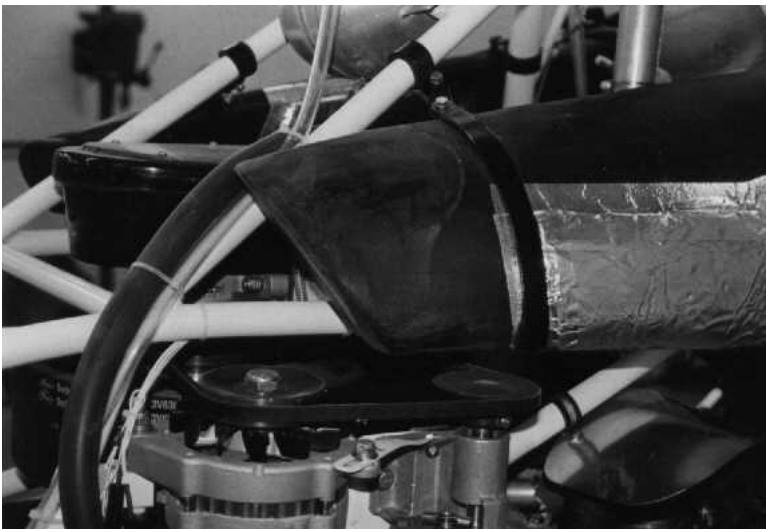

**Photo #17**

Be sure the rear bottom of the fuel tank does not rub on the water pump or the alternator on the passenger side.



**Photo #18**

Note the clearance of fuel tank and body. The fuel tanks should not rub on the body at any point.



**Photo #19**

Another view of the clearance between the fuel tank and the body on the pilot's side. When the tanks are properly located, mount them to the airframe with the retention straps. Note wires for the fuel gauge sender.

See photo #33 at the end of this section for installation of the vent hose between the tanks (seen at right in this photo). There should be some slack in the vent hose, yet it must not be higher than the top of the fuel tanks at any point.

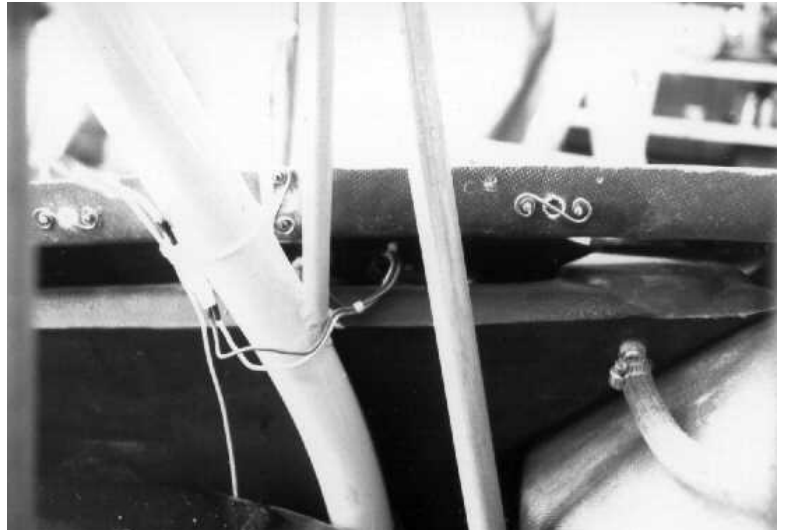

**Photo #20**

The fuel hoses should be tightened by hand only, until all components of the fuel system have been installed. Then, when hose routing is satisfactory, tighten the fittings with a wrench. Remember to grip the wrench close to the fittings (as shown) to help prevent over tightening.



**Photo #21**

Using template E25-1, make the fuel drain cock mounting bracket. Screw the fittings and drain cock into the tee, using Teflon tape on the threads. Mount the assembled drain cock on the bracket with nut plates and cushion loop clamps as shown.

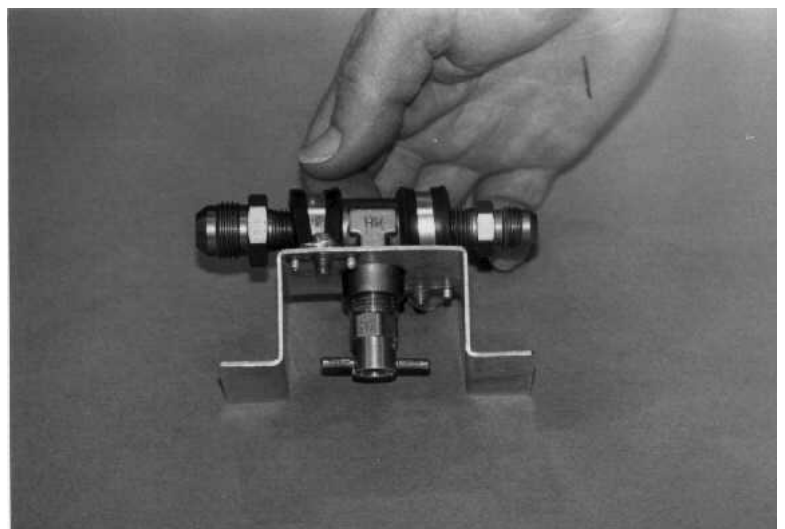

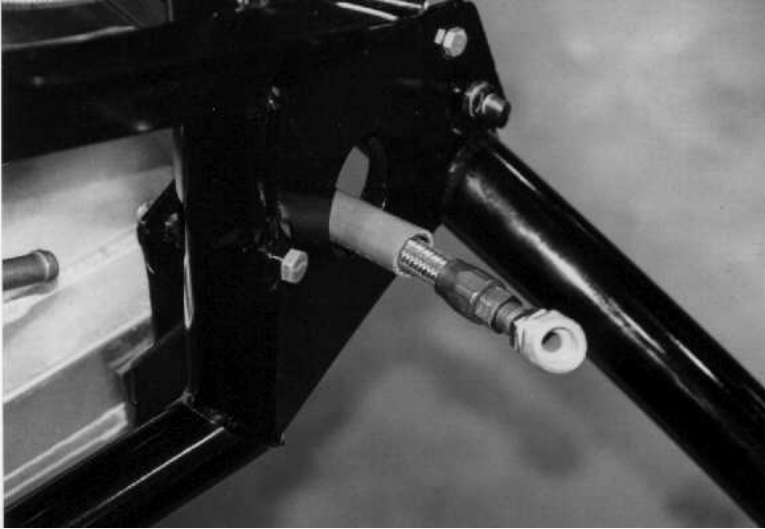

**Photo #22**

Route the hose from the pilot's side fuel tank to the drain, through the hole in the rear landing gear bracket. Cover the braided steel hose with a piece of rubber hose and secure it with wire ties to prevent chafing.

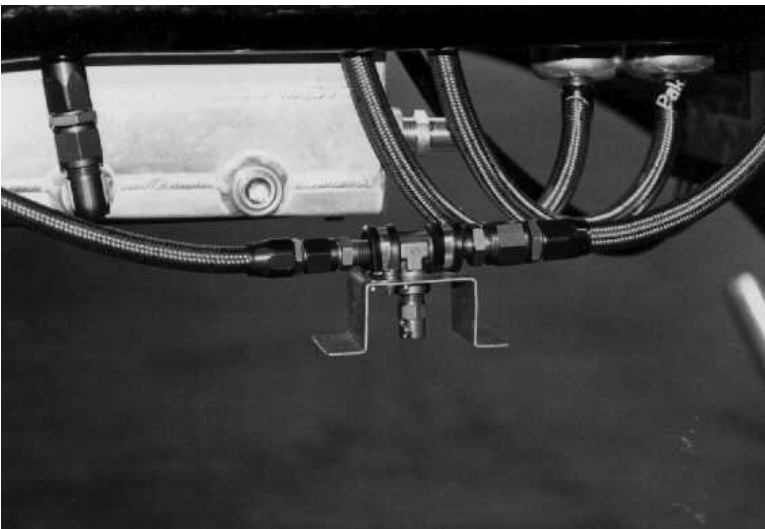

**Photo #23**

Fuel drain and bracket viewed from rear. When the fiberglass tub is installed later, the bracket will be secured to the tub in this location with screws and nut plates.



**Photo #24**

Install the fuel pumps. Mount them with the negative (black) electrical terminals facing each other and the positive (yellow) terminals away from each other. Make sure the ribs on the pumps are above the hose clamps as shown.

Note: Keep the openings plugged until the hoses are installed to help keep out dirt.

**Photo #25**

Mount the fuel shut-off valve/filter assembly, using the socket head cap screws, aluminum spacers, and hose clamp. Make sure the snap ring on the bottom of the valve is positioned so that it does not contact the spacers.

Install the hose from the passenger fuel tank to the "T" on the left side of the shut off valve assembly. Install the swivel "T" and the two hoses to the fuel pumps on the right side of the shut off valve assembly.

Note: This photo shows the push-pull cable, which will be installed on the floorpan later (see Section 22, Photo 18).

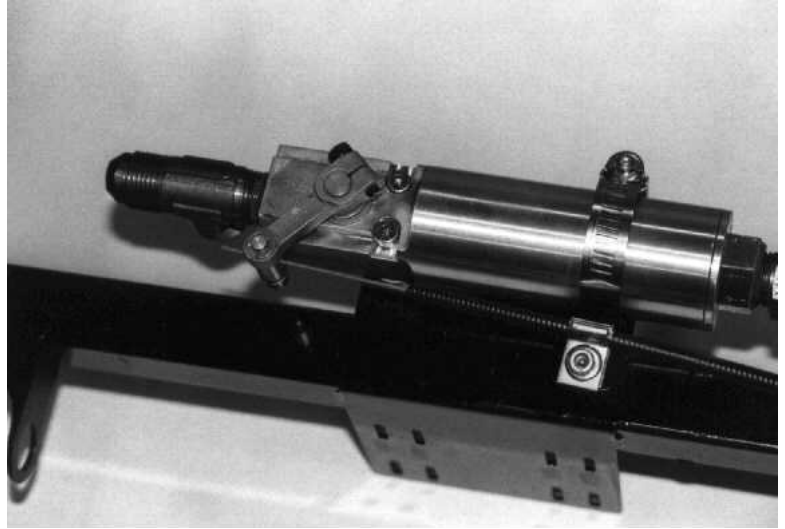

**Photo #26**

To install the braided hoses on the bottom of the fuel pumps, remove the protective tape from the end of the hose. Any frayed wires from the braiding can be trimmed with scissors or wire cutters if necessary. **CAUTION:** Handle carefully. The steel braid wires are sharp. Apply a light film of engine oil to the inside of the hose and the inlet on the pump for easier installation. Make sure the hose is pushed all the way up to the pump before tightening the clamp.

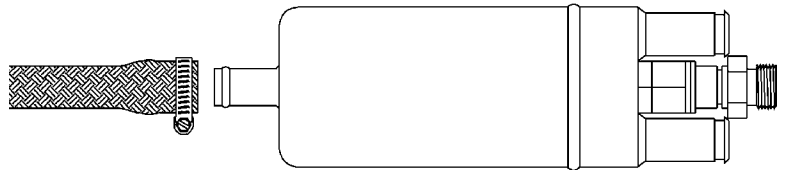

**Photo #27**

Install the hoses from the pumps to the filter. Adjust them so that the swivel "T" is accessible with a wrench. This will make it easier to remove the screen filter for maintenance later.

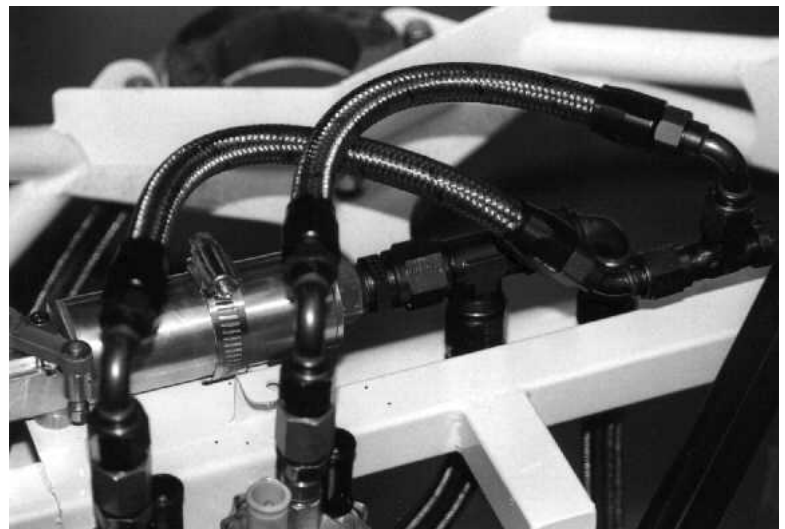

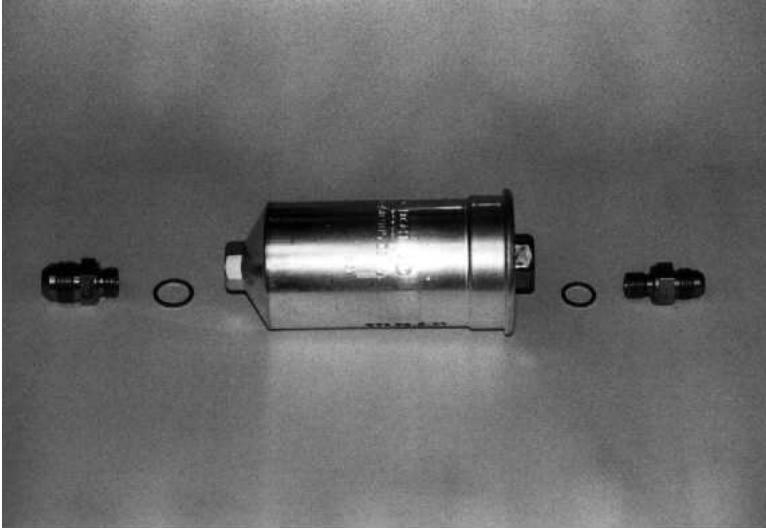

**Photo #28**

Screw the fittings into the fuel filter. Use the crush washers provided. Do not damage the crush washers by over tightening the fittings.

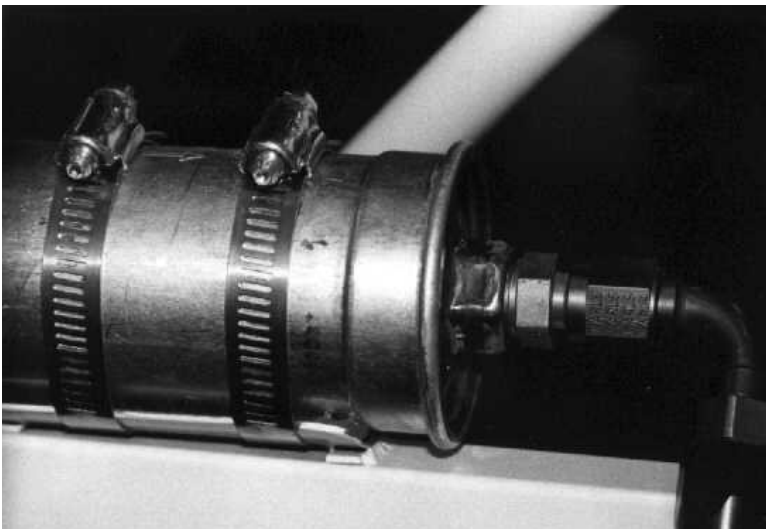

**Photo #29**

Cut the rubber to fit on the filter mount bracket and glue it in place with weatherstrip adhesive. Install the filter as shown, with the step to the pilot's side of the bracket. (An arrow on the filter indicates direction of flow.) Secure the filter with two hose clamps and install the hoses.

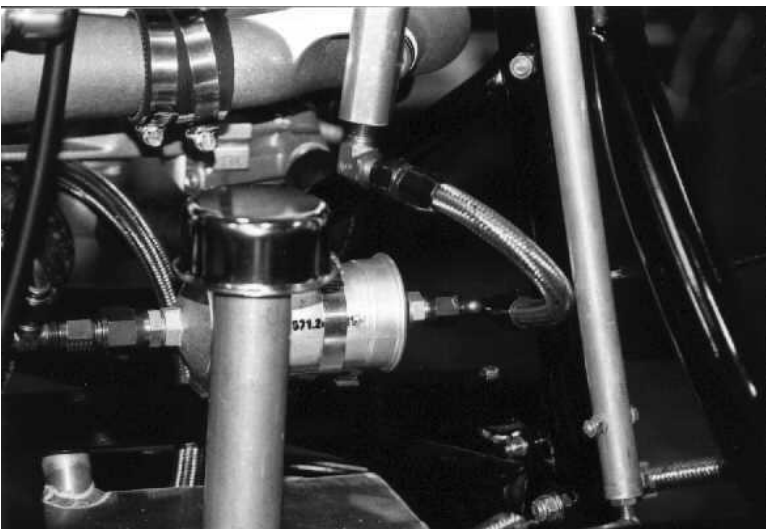

**Photo #30**

Route the hose from the filter to the fuel rail on the engine, pilot's side.

**Photo #31**

Mount the fuel pressure regulator to the bracket with the large nut and lock washer. Do not tighten the nut until after the hoses are fitted. This will allow the regulator to pivot on the bracket slightly for a better fit. Install the fuel pressure gauge sensor on the top fitting of the regulator.



**Photo #32**

Route the hose from the fuel rail on the engine (passenger side) to the bottom fitting of the fuel pressure regulator. Install the rubber hose from the right side of the regulator to the fitting on the plenum. Secure the hose with plastic hose clamps.

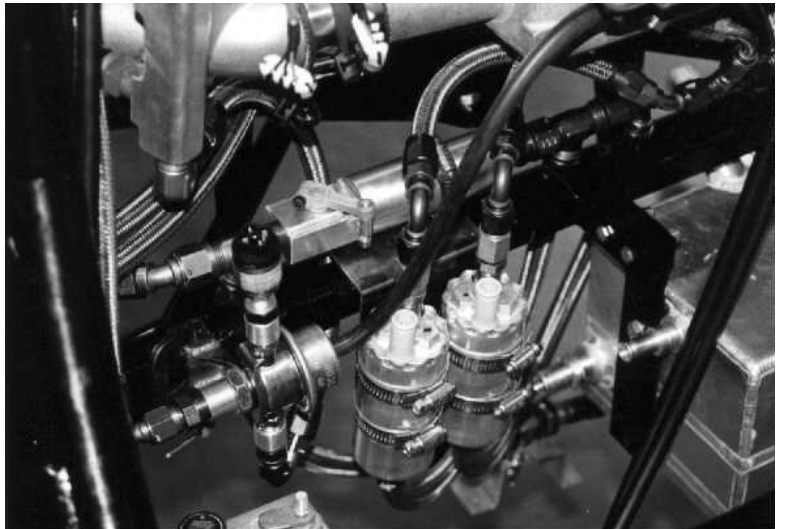

**Photo #33**

Assemble the "T" fitting, 45 degree fitting and hose bars as shown. Determine the best position to mount the "T" on the back of the seat bulkhead. This will be off center towards the passenger side. Make sure the braided steel hose has clearance around the oil bath and other components. Install the hose from the regulator to the "T". Cut the crossover hoses to the correct length and install them. Secure the "T" to the seat bulkhead using the cushion loop clamp with a 6-32 screw and nut. There should be some slack in the crossover hoses (they should not be pulled tight) and the hoses and "T" must not be higher than the top of the fuel tanks at any point.

